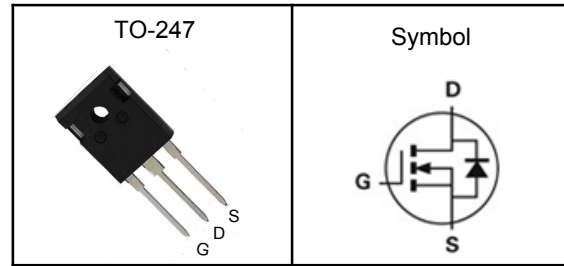

650V Super Junction Power MOSFET
Features

- Low drain-source on-resistance: $R_{DS(on)}=0.035(\Omega_{typ})$
- Very Low FOM ($R_{DS(on)} \times Q_g$)
- Extremely low switching loss
- 100% avalanche tested
- RoHS compliant

Applications

- Switch Mode Power Supply (SMPS)
- Uninterruptible Power Supply (UPS)
- Power Factor Correction (PFC)

Pin Description

V_{DSS}	650	V
$R_{DS(on)-Typ}$	35	m Ω
I_D	80	A

Absolute Maximum Ratings ($T_C=25^\circ\text{C}$, Unless Otherwise Noted)

Symbol	Parameter	N-Channel	Unit
V_{DSS}	Drain-Source Voltage	650	V
V_{GSS}	Gate-Source Voltage	± 30	V
T_J	Maximum Junction Temperature	-55 to 150	$^\circ\text{C}$
T_{STG}	Storage Temperature Range	-55 to 150	$^\circ\text{C}$
E_{AS}	Single Pulse Avalanche Energy ³	720	mJ
$I_{DM}^{①}$	300 μs Pulse Drain Current Tested	240	A
I_D	Continuous Drain Current	80	A
P_D	Maximum Power Dissipation	481	W
I_{AS}	Avalanche Current	12	A
E_{AR}	Repetitive Avalanche Energy	3.0	mJ
dv/dt	MOSFET dv/dt ruggedness, $V_{DS} = 0 \dots 400\text{V}$	50	V/ns
	Reverse diode dv/dt^3 $V_{DS}=0 \dots 400\text{V}$, $I_{SD} \leq I_D$	50	

Thermal Characteristics

Symbol	Parameter	Rating	Unit
$R_{\theta JA}$	Thermal Resistance Junction-Ambient ¹ (Max)	62	$^\circ\text{C}/\text{W}$
$R_{\theta JC}$	Thermal Resistance Junction-Case ¹ (Max)	0.26	$^\circ\text{C}/\text{W}$

Note ① : Max. current is limited by bonding wire.

Note ② : UIS tested and pulse width are limited by maximum junction temperature 150 $^\circ\text{C}$.

Note ③ : Surface Mounted on 1in² FR-4 board with 1oz.



650V Super Junction Power MOSFET

Electrical Characteristics ($T_J=25^{\circ}\text{C}$, Unless Otherwise Noted)

Symbol	Parameter	Test Conditions	Min	Typ	Max	Unit
Static Electrical Characteristics						
BV_{DSS}	Drain-Source Breakdown Voltage	$V_{GS}=0V, I_D=250\mu A$	650	---	---	V
I_{DSS}	Zero Gate Voltage Drain Current	$V_{DS}=650V, V_{GS}=0V$	---	---	5	μA
$V_{GS(th)}$	Gate Threshold Voltage	$V_{DS}=V_{GS}, I_D=250\mu A$	2.5	---	4.5	V
I_{GSS}	Gate Leakage Current	$V_{GS}=\pm 30V, V_{DS}=0V$	---	---	± 100	nA
$R_{DS(ON)}$	Drain-Source On-state Resistance	$V_{GS}=10V, I_D=25A$	---	35	41	$m\Omega$
R_G	Gate Resistance	$V_{DS}=0V, V_{GS}=0V, f=1MHz$	---	13	---	Ω
Dynamic Characteristics ^⑤						
C_{iss}	Input Capacitance	$V_{GS}=0V,$ $V_{DS}=50V,$ Freq.=1MHz	---	5960	---	pF
C_{oss}	Output Capacitance		---	490	---	
C_{riss}	Reverse Transfer Capacitance		---	30	---	
$T_{d(on)}$	Turn-on Delay Time	$V_{DD}=400V, R_G=1.9\Omega,$ $I_D=44.4A, V_{GS}=13V$	---	22	---	nS
T_r	Turn-on Rise Time		---	10	---	
$T_{d(off)}$	Turn-off Delay Time		---	120	---	
T_f	Turn-off Fall Time		---	8	---	
Q_g	Total Gate Charge	$V_{DD}=520V, V_{GS}=10V,$ $I_D=72A$	---	133	---	nC
Q_{gs}	Gate-Source Charge		---	27	---	
Q_{gd}	Gate-Drain Charge		---	41	---	
Source-Drain Characteristics ($T_J=25^{\circ}\text{C}$)						
V_{SD} ^④	Diode Forward Voltage	$I_S=50A, V_{GS}=0V$	---	0.8	1.2	V
t_{rr}	Reverse Recovery Time	$V_R=400V, I_F=44.4A,$	---	390	---	nS
Q_{rr}	Reverse Recovery Charge	$di/dt=100A/\mu s, T_J=25^{\circ}\text{C}$	---	9	---	nC

Note ④ : Pulse test (pulse width $\leq 300\mu s$, duty cycle $\leq 2\%$).

Note ⑤ : Guaranteed by design, not subject to production testing.

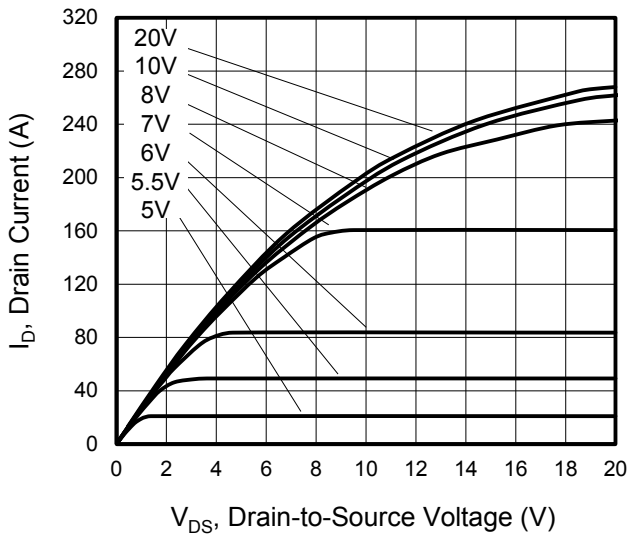
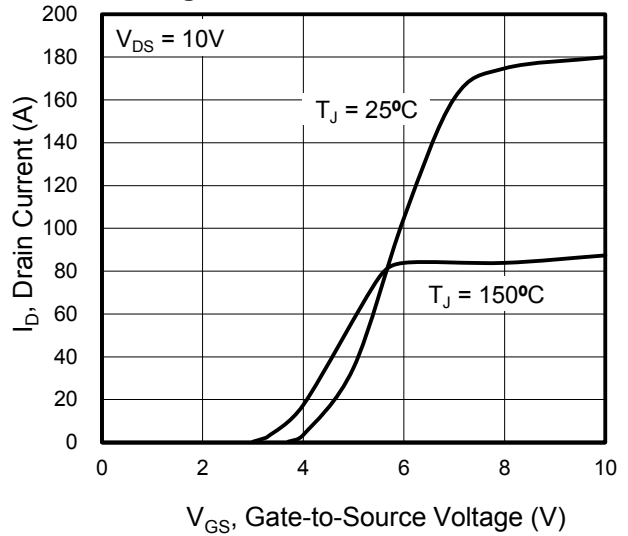
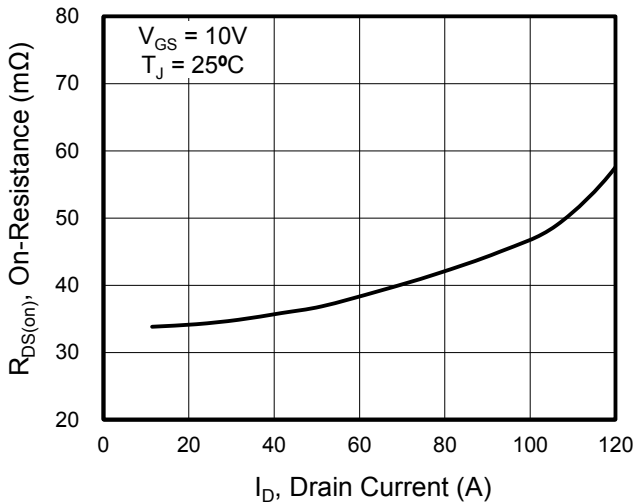
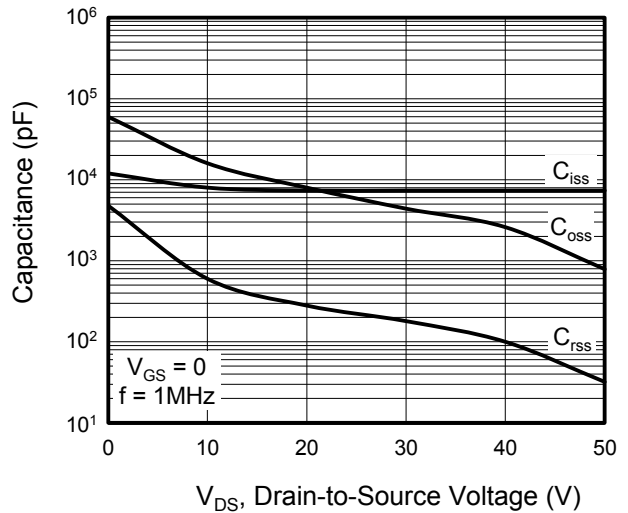
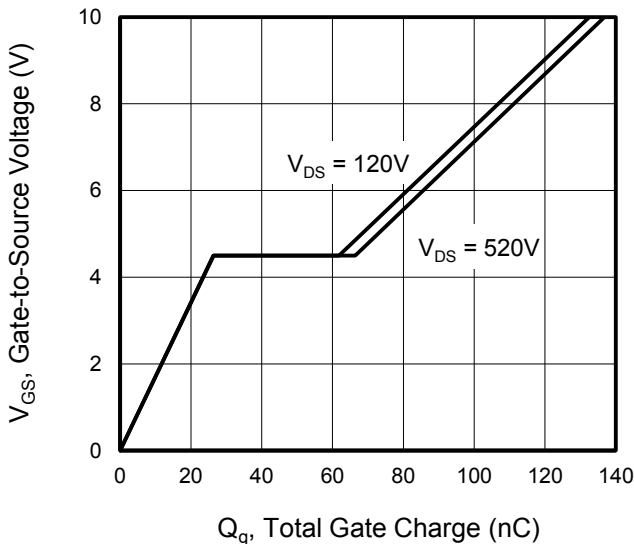
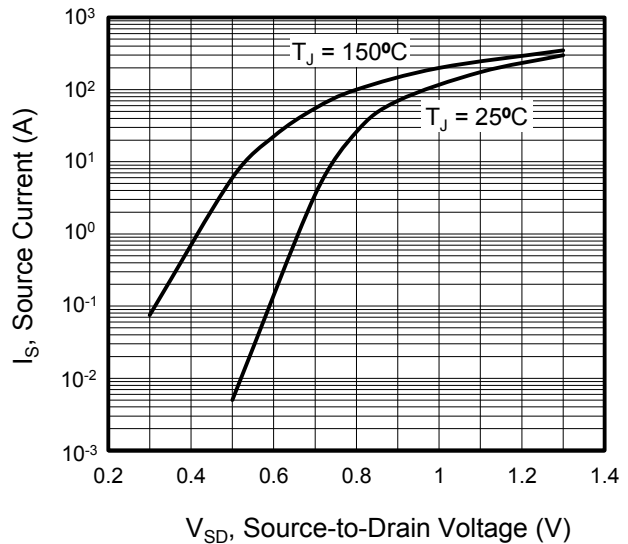
650V Super Junction Power MOSFET
Typical Characteristics
Figure 1. Output Characteristics

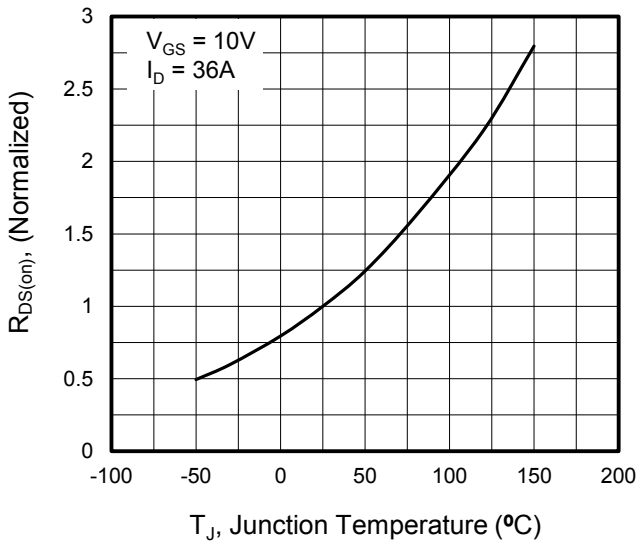
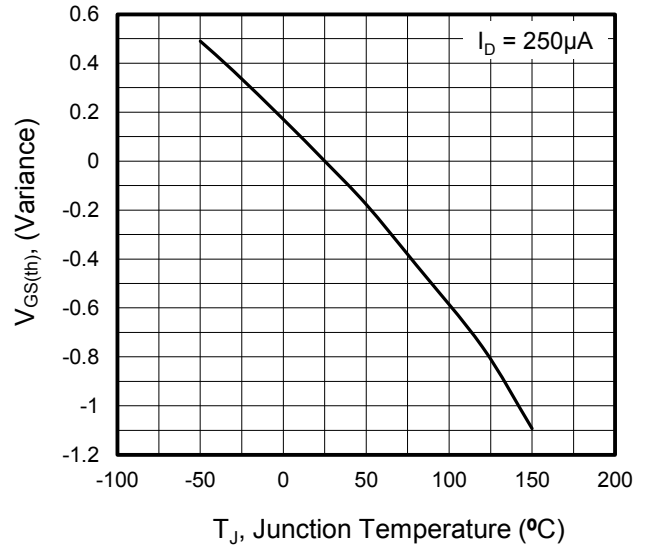
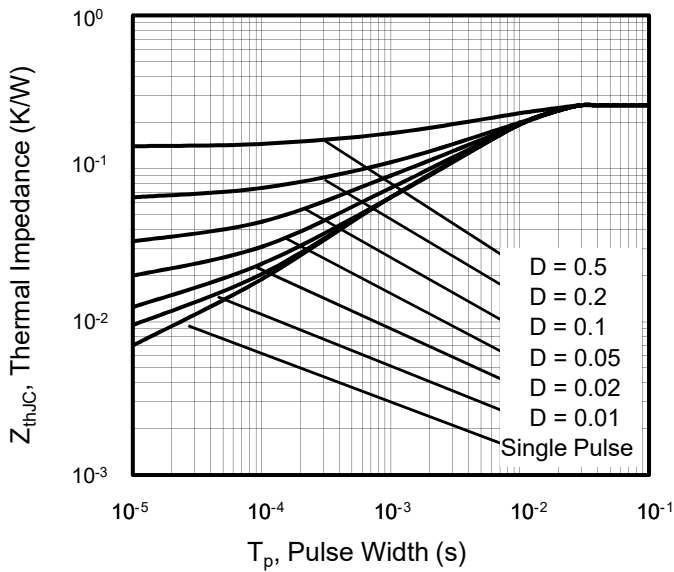
Figure 2. Transfer Characteristics

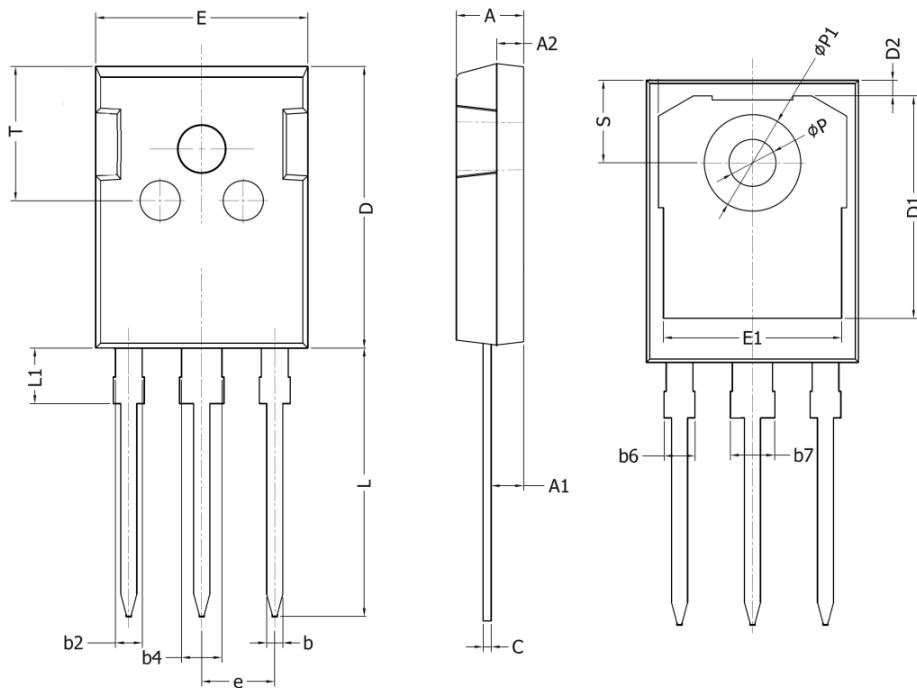
Figure 3. On-Resistance vs. Drain Current

Figure 4. Capacitance

Figure 5. Gate Charge

Figure 6. Body Diode Forward Voltage

650V Super Junction Power MOSFET
Figure 7. On-Resistance vs. Temperature

Figure 8. Threshold Voltage vs. Temperature

Figure 9. Transient Thermal Impedance

650V Super Junction Power MOSFET
TO-247 Package Outline Dimensions

Symbol	Dimensions In Millimeters	
	Min.	Max.
A	4.90	5.20
A1	2.31	2.51
A2	1.9	2.1
b	1.16	1.26
b2	1.96	2.06
b4	2.96	3.06
b6	-	2.25
b7	-	3.25
C	0.59	0.66
D	20.90	21.20
D1	16.25	16.85
D2	1.05	1.35
E	15.75	16.10
E1	13.00	13.60
e	5.436 BSC	
L	19.80	20.20
L1	-	4.30
P	3.40	3.60
P1	7.00	7.40
S	6.05	6.25
T	9.80	10.20