

**Silicon Carbide Schottky Diode**

$V_{RRM}$	=	1200 V
$I_F (T_c=151\text{ }^\circ\text{C})$	=	40 A**
$Q_C$	=	252 nC**

**Features**

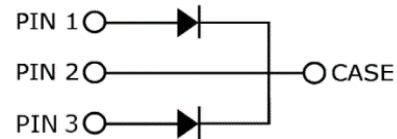
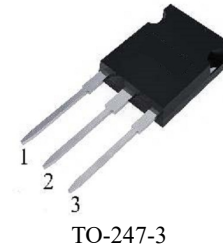
- 1.2kV Schottky Rectifier
- Zero Reverse Recovery Current
- High-Frequency Operation
- Temperature-Independent Switching
- Extremely Fast Switching

**Benefits**

- Replace Bipolar with Unipolar Rectifiers
- Essentially No Switching Losses
- High Efficiency
- Reduction of Heat Sink Requirements
- Parallel Devices Without Thermal Runaway

**Applications**

- Switching Mode Power Supply
- Boost Diodes in PFC
- DC/DC Converters
- AC/DC Converters
- Free Wheeling Diodes in Inverter

**Package**

**Maximum Ratings** (  $T_c = 25\text{ }^\circ\text{C}$  unless otherwise specified )

Symbol	Parameter	Value	Unit	Test Conditions	Note
$V_{RRM}$	Repetitive Peak Reverse Voltage	1200	V		
$V_{RSM}$	Surge Peak Reverse Voltage	1300	V		
$V_R$	DC Peak Reverse Voltage	1200	V		
$I_F$	Continuous Forward Current	60/120 28/56 20/40	A	$T_c=25\text{ }^\circ\text{C}$ $T_c=135\text{ }^\circ\text{C}$ $T_c=151\text{ }^\circ\text{C}$	Fig. 3
$I_{FSM}$	Non-Repetitive Forward Surge Current	160*	A	$T_c=25\text{ }^\circ\text{C}$ , $t_p=10\text{ ms}$ , Half Sine Pulse	
$P_{tot}$	Power Dissipation	263* 114*	W	$T_c=25\text{ }^\circ\text{C}$ $T_c=110\text{ }^\circ\text{C}$	Fig. 4
$T_J$	Operating Junction Range	-55 to +175	$^\circ\text{C}$		
$T_{stg}$	Storage Temperature Range	-55 to +175	$^\circ\text{C}$		

\*Per Leg, \*\*Per Device

**Silicon Carbide Schottky Diode**
**Electrical Characteristics (Per Leg)**

Symbol	Parameter	Typ.	Max.	Unit	Test Conditions	Note
$V_F$	Forward Voltage	1.45 2	1.7 2.6	V	$I_F = 20\text{ A}, T_J = 25\text{ }^\circ\text{C}$ $I_F = 20\text{ A}, T_J = 175\text{ }^\circ\text{C}$	Fig. 1
$I_R$	Reverse Current	15 50	200 500	$\mu\text{A}$	$V_R = 1200\text{ V}, T_J = 25\text{ }^\circ\text{C}$ $V_R = 1200\text{ V}, T_J = 175\text{ }^\circ\text{C}$	Fig. 2
$Q_C$	Total Capacitive Charge	126		nC	$V_R = 800\text{ V}, I_F = 20\text{ A},$ $T_J = 25\text{ }^\circ\text{C}$	Fig. 6
$C$	Total Capacitance	1702 120 95		pF	$V_R = 0\text{ V}, T_J = 25\text{ }^\circ\text{C}, f = 1\text{ MHz}$ $V_R = 400\text{ V}, T_J = 25\text{ }^\circ\text{C}, f = 1\text{ MHz}$ $V_R = 800\text{ V}, T_J = 25\text{ }^\circ\text{C}, f = 1\text{ MHz}$	Fig. 5
$E_C$	Capacitance Stored Energy	32.5		$\mu\text{J}$	$V_R = 800\text{ V}$	Fig. 7

Note: This is a majority carrier diode, so there is no reverse recovery charge.

**Thermal Characteristics**

Symbol	Parameter	Min.	Typ.	Max.	Unit	Note
$R_{\theta JC}$	Thermal Resistance from Junction to Case		*0.57 **0.29		$^\circ\text{C/W}$	Fig.8

\*Per Leg, \*\*Per Device

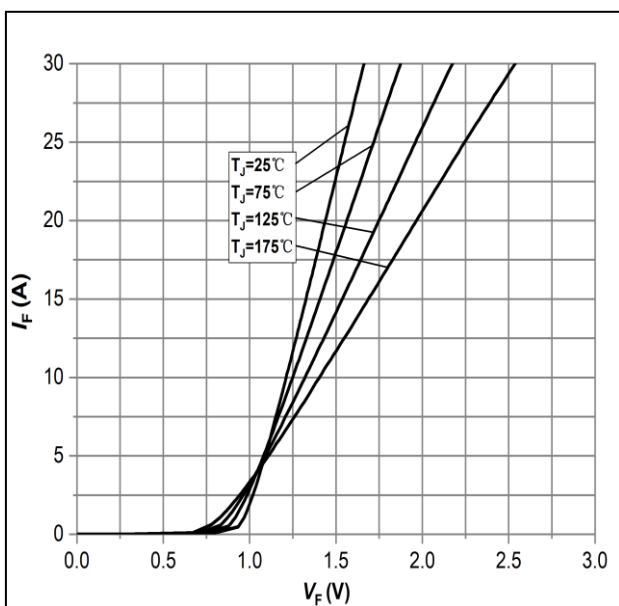
**Typical Performance (Per Leg)**


Figure 1: Forward Characteristics

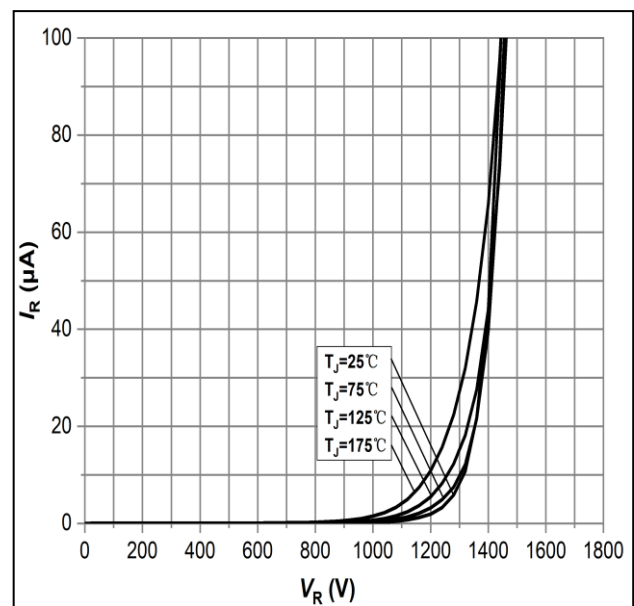


Figure 2: Reverse Characteristics

**Silicon Carbide Schottky Diode**

**Typical Performance (Per Leg)**

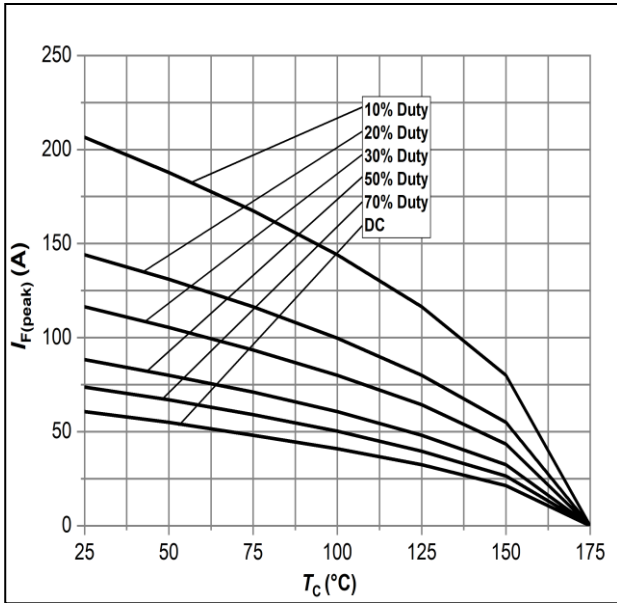


Figure 3: Current Derating

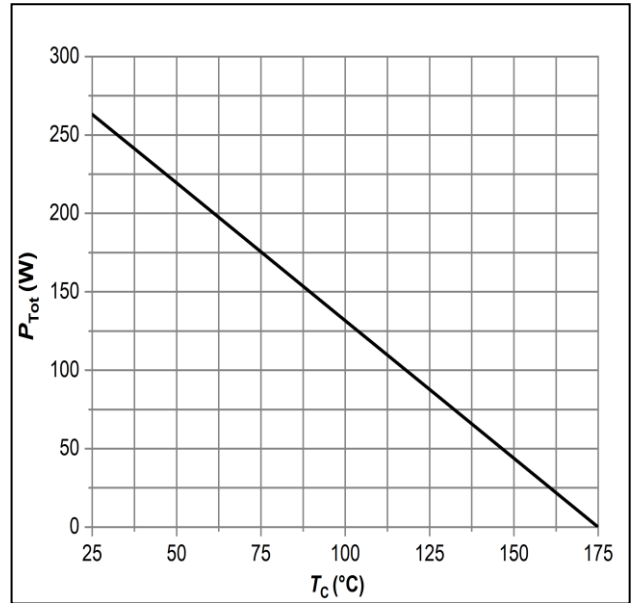


Figure 4: Power Derating

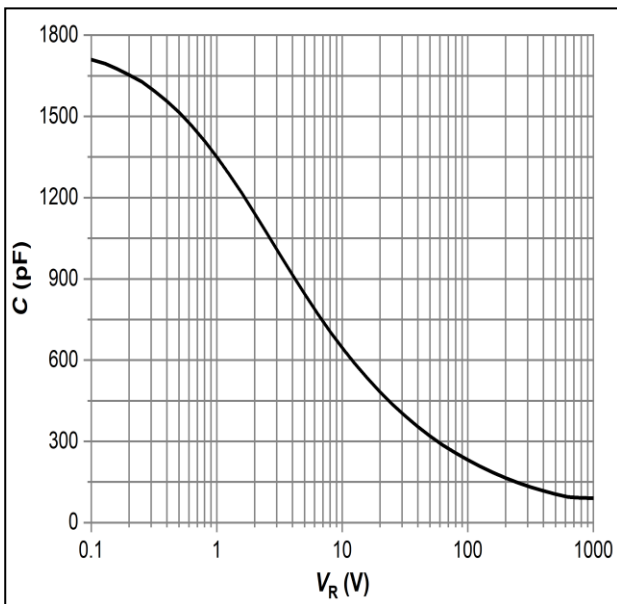


Figure 5: Capacitance vs. Reverse Voltage

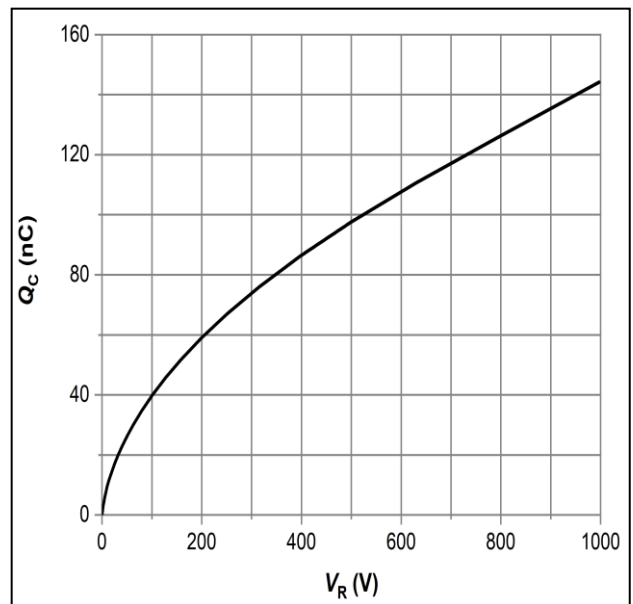


Figure 6: Total Capacitance Charge vs. Reverse Voltage

**Silicon Carbide Schottky Diode**

**Typical Performance (Per Leg)**

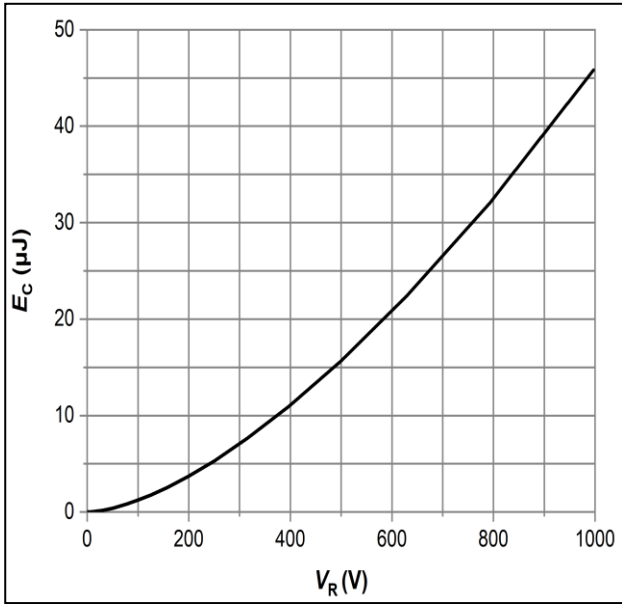


Figure 7: Typical Capacitance Stored Energy

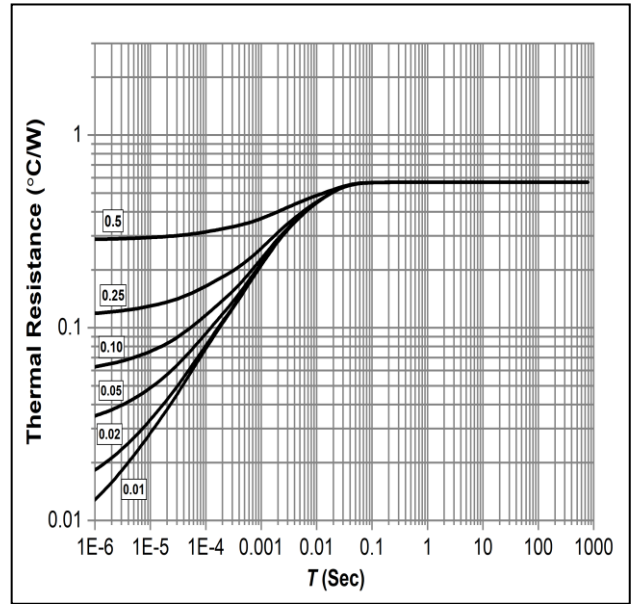
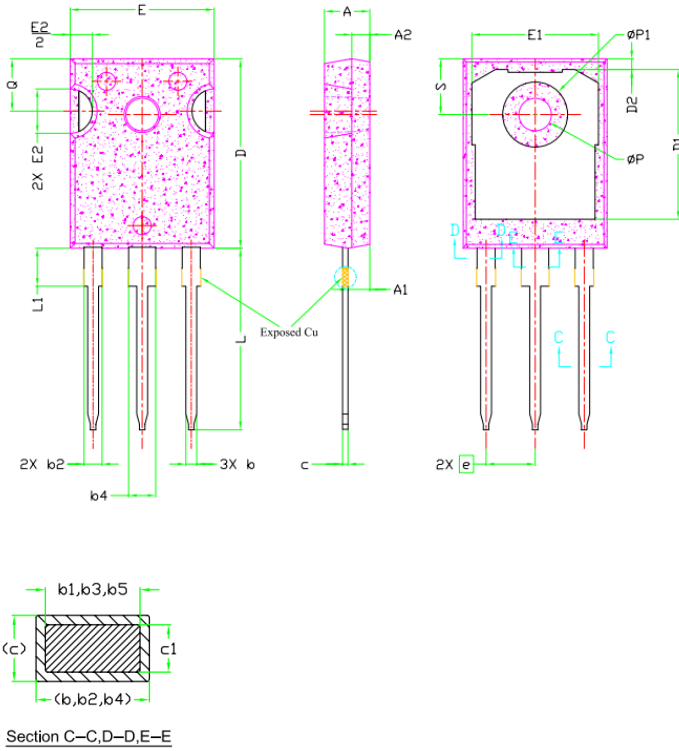


Figure 8: Transient Thermal Impedance

**Silicon Carbide Schottky Diode**
**Package Dimensions**

Package: TO-247-3



SYMBOL	DIMENSIONS			NOTES
	Min.	NOM	Max.	
A	4.83	5.02	5.21	
A1	2.29	2.41	2.55	
A2	1.50	2.00	2.49	
b	1.12	1.20	1.33	
b1	1.12	1.20	1.28	
b2	1.91	2.00	2.39	6
b3	1.91	2.00	2.34	
b4	2.87	3.00	3.22	6,8
b5	2.87	3.00	3.18	
C	0.55	0.60	0.65	6
c1	0.55	0.60	0.65	
D	20.80	20.95	21.10	4
D1	16.25	16.55	17.65	5
D2	0.51	1.19	1.35	
E	15.75	15.94	16.13	4
E1	13.46	14.02	14.16	5
E2	4.32	4.91	5.49	3
e	5.44BSC			
L	19.81	20.07	20.32	
L1	4.10	4.19	4.40	6
ØP	3.56	3.61	3.65	7
ØP1	7.19REF.			
Q	5.39	5.79	6.20	
S	6.04	6.17	6.30	

NOTE : Dimension L, M, W apply for Solder Dip Finish