

## N-Channel Enhancement Mode MOSFET

### Features

- Fast switching speed
- Reliable and Rugged
- ROHS Compliant
- 100% UIS and Rg Tested

### Pin Description

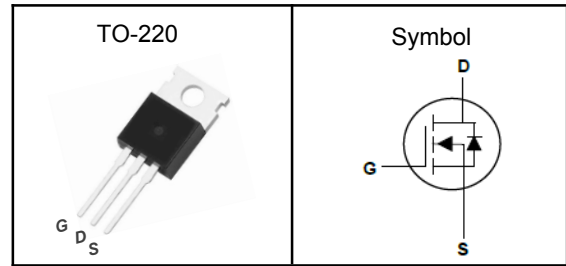

### Applications

- Power Management in Desktop Computer
- DC/DC Converters

$V_{DSS}$	650	V
$R_{DS(ON)-Typ}$	2.1	$\Omega$
$I_D$	4	A

### Absolute Maximum Ratings ( $T_J=25^\circ\text{C}$ , Unless Otherwise Noted)

Symbol	Parameter	N-Channel	Unit
$V_{DSS}$	Drain-Source Voltage	650	V
$V_{GSS}$	Gate-Source Voltage	$\pm 30$	V
$T_J$	Maximum Junction Temperature	-55 to 150	$^\circ\text{C}$
$T_{STG}$	Storage Temperature Range	-55 to 150	$^\circ\text{C}$
$E_{AS}$	Single Pulse Avalanche Energy <sup>3</sup>	240	mJ
$I_{DM}^{①}$	Pulse Drain Current Tested	16	A
$I_D$	Continuous Drain Current	$T_c=25^\circ\text{C}$ 4	A
$P_D$	Maximum Power Dissipation	$T_c=25^\circ\text{C}$ 80	W

### Thermal Characteristics

Symbol	Parameter	Rating	Unit
$R_{\theta JA}$	Thermal Resistance Junction-Ambient <sup>1</sup> (Max)	60	$^\circ\text{C}/\text{W}$
$R_{\theta JC}$	Thermal Resistance Junction-Case <sup>1</sup>	1.66	$^\circ\text{C}/\text{W}$

Note ① : Max. current is limited by bonding wire.

Note ② : UIS tested and pulse width are limited by maximum junction temperature 150 $^\circ\text{C}$ .

Note ③ : Surface Mounted on 1in<sup>2</sup> FR-4 board with 1oz.



**N-Channel Enhancement Mode MOSFET**

**Electrical Characteristics** ( $T_J=25^{\circ}\text{C}$ , Unless Otherwise Noted)

Symbol	Parameter	Test Conditions	Min	Typ	Max	Unit
<b>Static Electrical Characteristics</b>						
$BV_{DSS}$	Drain-Source Breakdown Voltage	$V_{GS}=0V, I_D=250\mu A$	650	---	---	V
$I_{DSS}$	Zero Gate Voltage Drain Current	$V_{DS}=650V, V_{GS}=0V$	---	---	1	$\mu A$
$V_{GS(th)}$	Gate Threshold Voltage	$V_{DS}=V_{GS}, I_D=250\mu A$	2	---	4	V
$I_{GSS}$	Gate Leakage Current	$V_{GS}=\pm 30V, V_{DS}=0V$	---	---	$\pm 100$	nA
$R_{DS(ON)}$	Drain-Source On-state Resistance	$V_{GS}=10V, I_D=2A$	---	2.1	2.4	$\Omega$
<b>Dynamic Characteristics</b> <sup>⑤</sup>						
$C_{iss}$	Input Capacitance	$V_{GS}=0V,$ $V_{DS}=25V,$ $Freq.=1MHz$	---	490	---	pF
$C_{oss}$	Output Capacitance		---	45	---	
$C_{rss}$	Reverse Transfer Capacitance		---	6	---	
$T_{d(on)}$	Turn-on Delay Time	$V_{DD}=325V, R_G=25\Omega,$ $I_D=4A$	---	20	---	nS
$T_r$	Turn-on Rise Time		---	55	---	
$T_{d(off)}$	Turn-off Delay Time		---	70	---	
$T_f$	Turn-off Fall Time		---	50	---	
$Q_g$	Total Gate Charge	$V_{DD}=400V, V_{GS}=10V,$ $I_D=4A$	---	10	---	nC
$Q_{gs}$	Gate-Source Charge		---	2	---	
$Q_{gd}$	Gate-Drain Charge		---	5	---	
<b>Source-Drain Characteristics</b> ( $T_J=25^{\circ}\text{C}$ )						
$V_{SD}$	Diode Forward Voltage <sub>z</sub>	$V_{GS}=0V, I_S=4A, T_J=25^{\circ}\text{C}$	---	---	1.4	V
$t_{rr}$	Reverse Recovery Time	$V_R=400V, I_F=4A,$ $di/dt=100A/\mu s, T_J=25^{\circ}\text{C}$	---	390	---	nS
$Q_{rr}$	Reverse Recovery Charge		---	2.2	---	nC

Note ④ : Pulse test (pulse width $\leq$ 300us, duty cycle $\leq$ 2%).

Note ⑤ : Guaranteed by design, not subject to production testing.

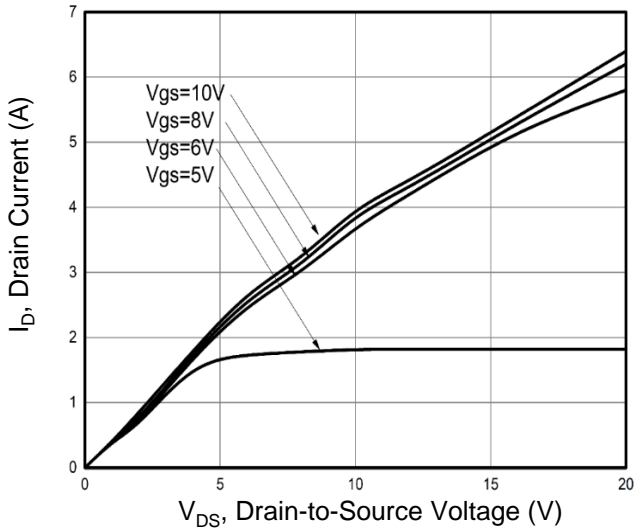
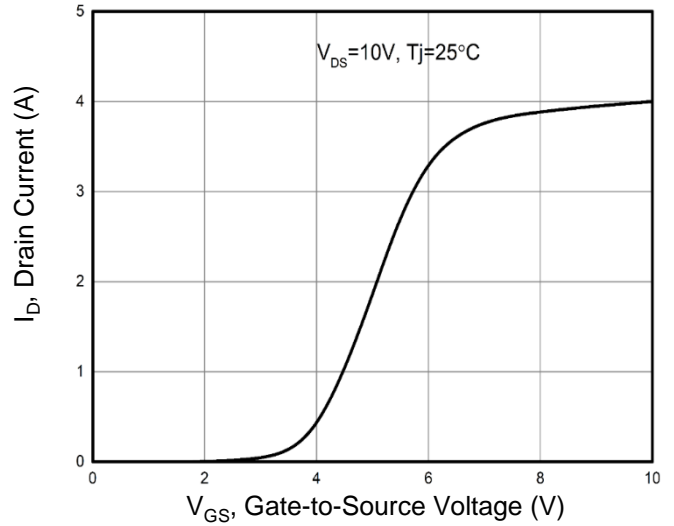
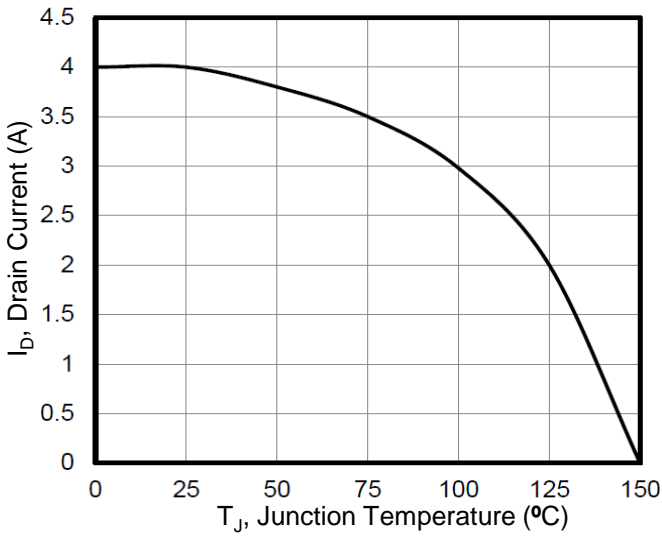
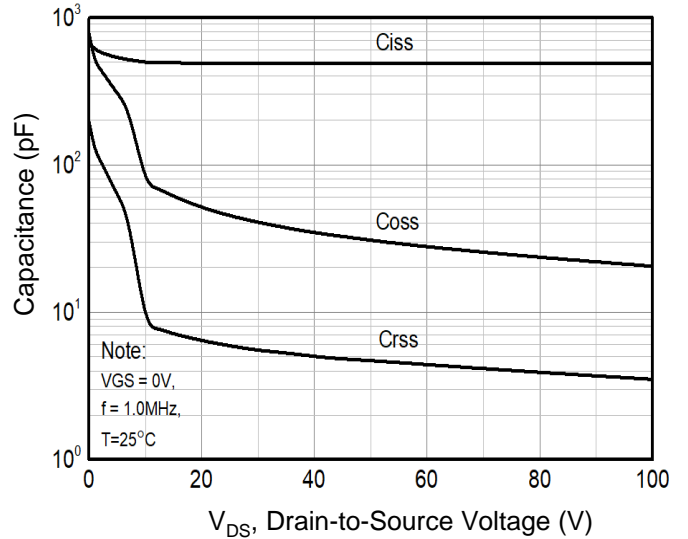
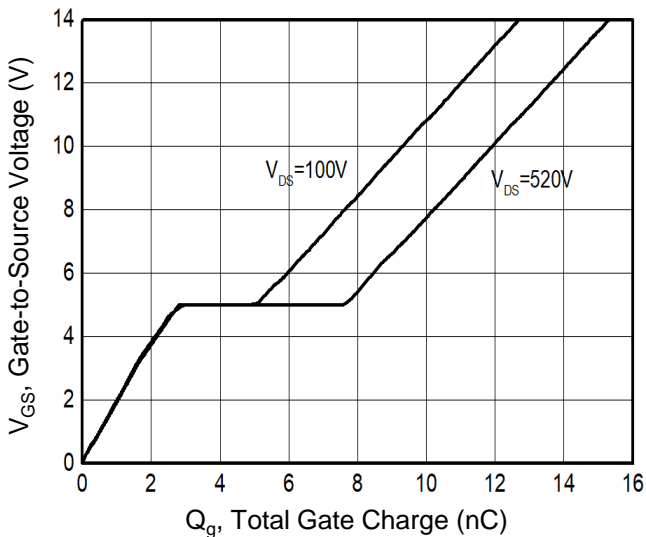
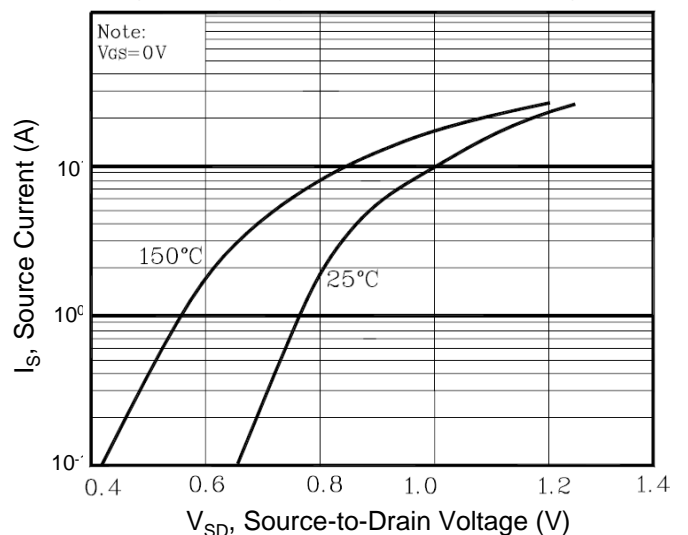
**N-Channel Enhancement Mode MOSFET**
**Typical Characteristics**
**Figure 1. Output Characteristics**

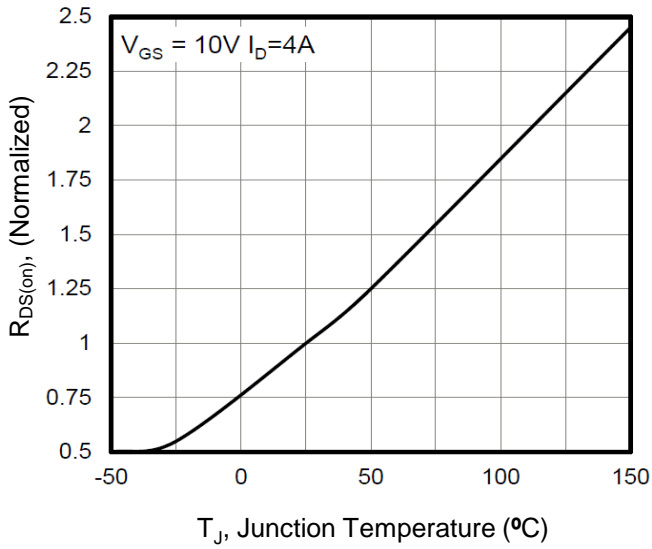
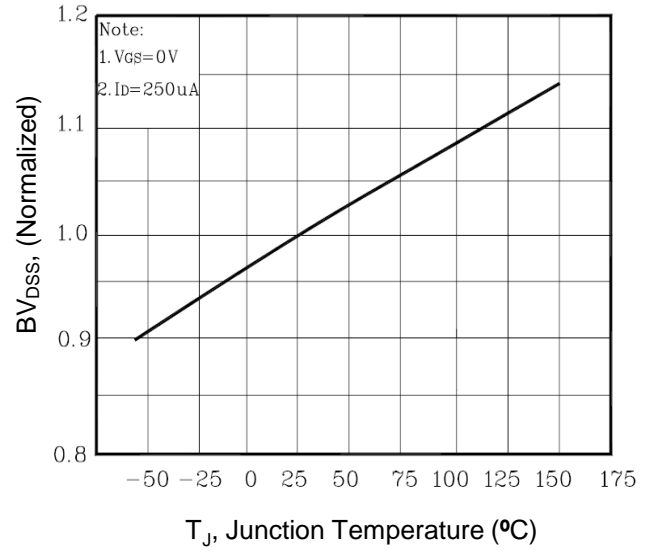
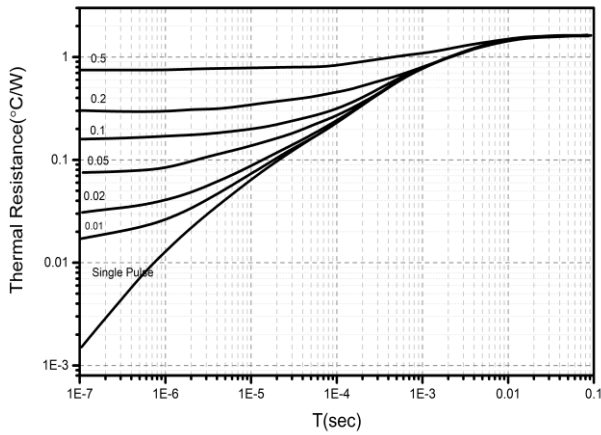
**Figure 2. Transfer Characteristics**

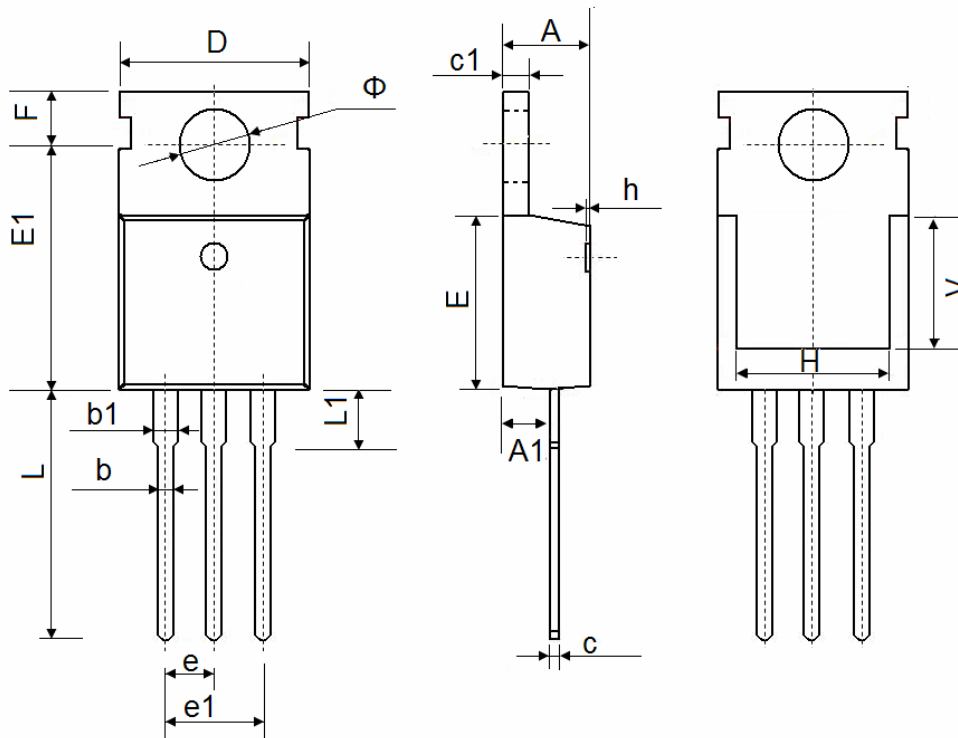
**Figure 3. Drain Current vs. Temperature**

**Figure 4. Capacitance**

**Figure 5. Gate Charge**

**Figure 6. Body Diode Forward Voltage**

**N-Channel Enhancement Mode MOSFET**
**Figure 7. On-Resistance vs. Temperature**

**Figure 8.  $BV_{DSS}$  vs. Temperature**

**Figure 9. Transient Thermal Impedance  
(TO-220 TO-252 )**

**N-Channel Enhancement Mode MOSFET**
**TO-220 Package Outline Data**

Symbol	Dimensions In Millimeters	
	Min.	Max.
A	4.350	4.650
A1	2.250	2.550
b	0.710	0.910
b1	1.170	1.400
c	0.330	0.650
c1	1.200	1.400
D	9.910	10.250
E	8.9500	9.750
E1	12.650	12.950
e	2.540 TYP.	
e1	4.980	5.180
F	2.650	2.950
H	7.900	8.100
h	0.000	0.300
L	12.700	13.500
L1	2.850	3.250
V	7.500 REF.	
Φ	3.400	3.800