

N-Channel Enhancement Mode MOSFET

Features

- Fast switching speed
- Reliable and Rugged
- ROHS Compliant
- 100% UIS and Rg Tested

Applications

- Power Management in Desktop Computer
- DC/DC Converters

Pin Description

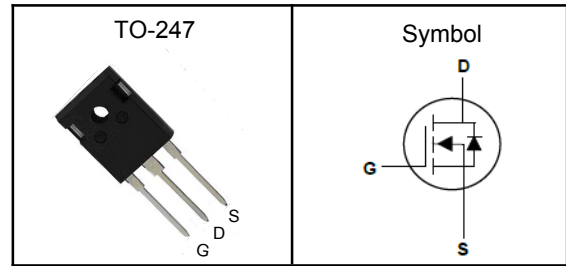

V_{DSS}	500	V
$R_{DS(ON)-Typ}$	0.08	Ω
I_D	45	A

Absolute Maximum Ratings ($T_J=25^\circ\text{C}$, Unless Otherwise Noted)

Symbol	Parameter	N-Channel	Unit
V_{DSS}	Drain-Source Voltage	500	V
V_{GSS}	Gate-Source Voltage	± 30	V
T_J	Maximum Junction Temperature	-55 to 150	$^\circ\text{C}$
T_{STG}	Storage Temperature Range	-55 to 150	$^\circ\text{C}$
E_{AS}	Single Pulse Avalanche Energy ^③	500	mJ
$I_{DM}^{①}$	Pulse Drain Current Tested	112	A
I_D	Continuous Drain Current	$T_c=25^\circ\text{C}$ 45	A
P_D	Maximum Power Dissipation	$T_c=25^\circ\text{C}$ 360	W

Thermal Characteristics

Symbol	Parameter	Rating	Unit
$R_{\theta JA}$	Thermal Resistance Junction-Ambient ^①	62	$^\circ\text{C}/\text{W}$
$R_{\theta JC}$	Thermal Resistance Junction-Case ^①	0.45	$^\circ\text{C}/\text{W}$

Note ① : Max. current is limited by bonding wire.

Note ② : UIS tested and pulse width are limited by maximum junction temperature 150°C .

Note ③ : Surface Mounted on 1in^2 FR-4 board with 1oz.



N-Channel Enhancement Mode MOSFET

Electrical Characteristics ($T_J=25^{\circ}\text{C}$, Unless Otherwise Noted)

Symbol	Parameter	Test Conditions	Min	Typ	Max	Unit
Static Electrical Characteristics						
BV_{DSS}	Drain-Source Breakdown Voltage	$V_{GS}=0V, I_D=250\mu A$	500	---	---	V
I_{DSS}	Zero Gate Voltage Drain Current	$V_{DS}=500V, V_{GS}=0V$	---	---	1	μA
$V_{GS(th)}$	Gate Threshold Voltage	$V_{DS}=V_{GS}, I_D=250\mu A$	2.5	---	4.5	V
I_{GSS}	Gate Leakage Current	$V_{GS}=\pm 30V, V_{DS}=0V$	---	---	± 10	μA
$R_{DS(ON)}$	Drain-Source On-state Resistance	$V_{GS}=10V, I_D=22.5A$	---	0.08	0.10	Ω
Dynamic Characteristics ^⑤						
C_{iss}	Input Capacitance	$V_{GS}=0V,$ $V_{DS}=25V,$ $Freq.=1MHz$	---	7050	---	pF
C_{oss}	Output Capacitance		---	740	---	
C_{rss}	Reverse Transfer Capacitance		---	23	---	
$T_{d(on)}$	Turn-on Delay Time	$V_{DD}=250V,$ $V_{GS}=10V, R_G=25\Omega,$ $I_D=45A$	---	84	---	nS
T_r	Turn-on Rise Time		---	87	---	
$T_{d(off)}$	Turn-off Delay Time		---	500	---	
T_f	Turn-off Fall Time		---	170	---	
Q_g	Total Gate Charge	$V_{DD}=400V,$ $V_{GS}=10V, I_D=45A$	---	130	---	nC
Q_{gs}	Gate-Source Charge		---	33	---	
Q_{gd}	Gate-Drain Charge		---	43	---	
Source-Drain Characteristics ($T_J=25^{\circ}\text{C}$)						
V_{SD}	Diode Forward Voltage ²	$V_{GS}=0V, I_S=22.5A, T_J=25^{\circ}\text{C}$	---	0.8	1.4	V
t_{rr}	Reverse Recovery Time	$I_F=45A,$ $di/dt=100A/\mu s, T_J=25^{\circ}\text{C}$	---	470	---	nS
Q_{rr}	Reverse Recovery Charge		---	8	---	nC

Note ④ : Pulse test (pulse width $\leq 300\mu s$, duty cycle $\leq 2\%$).

Note ⑤ : Guaranteed by design, not subject to production testing.

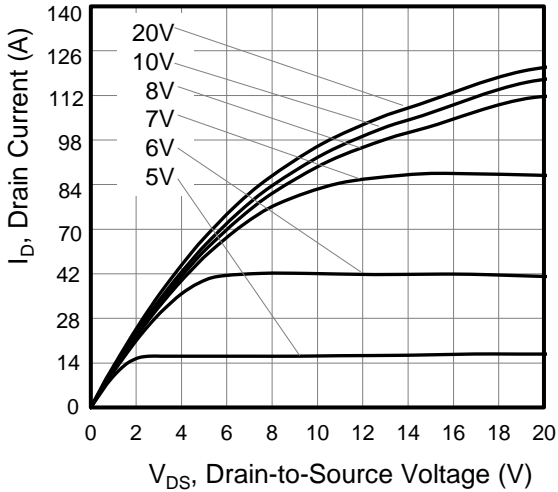
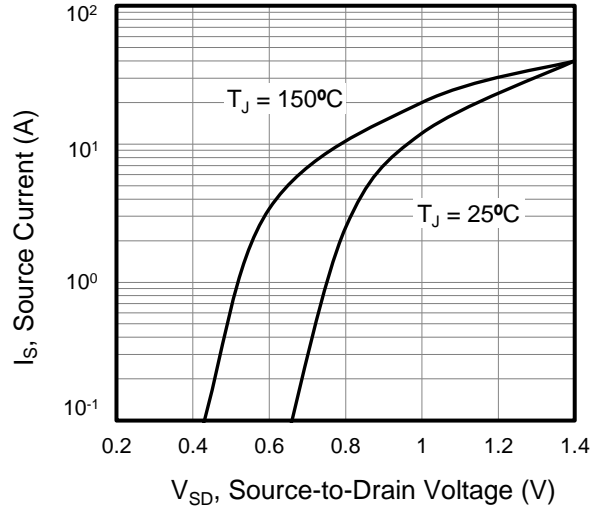
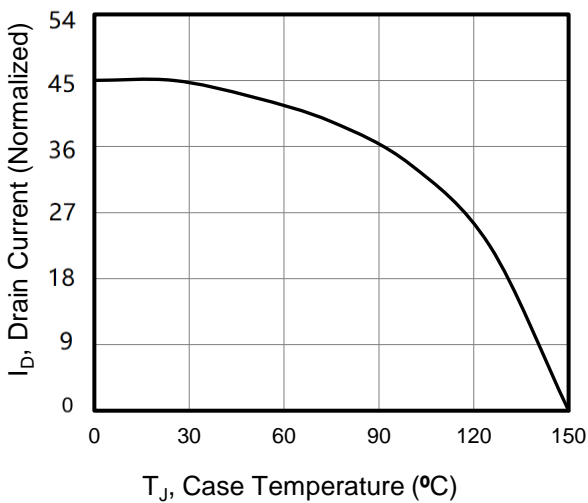
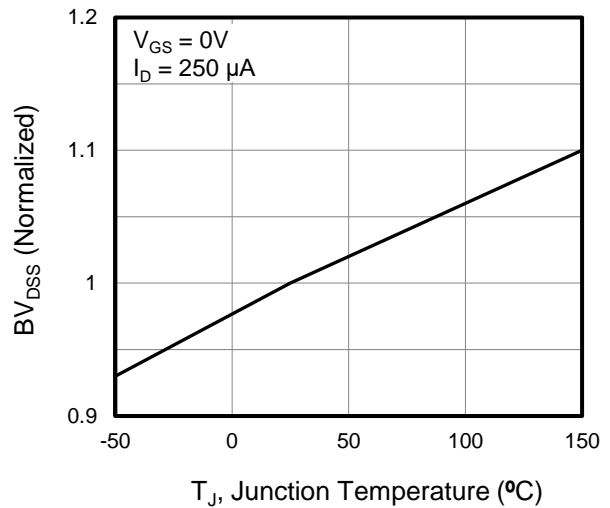
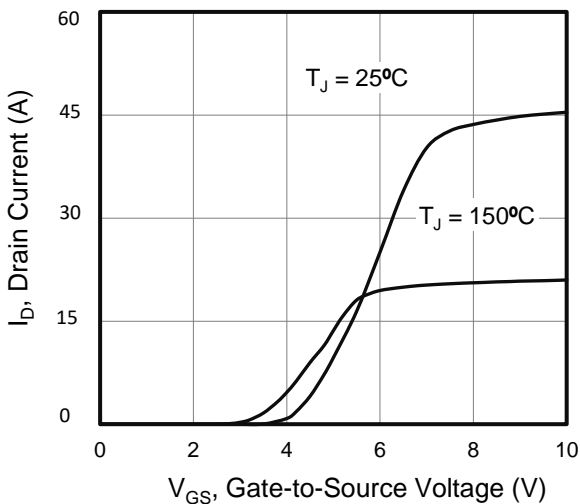
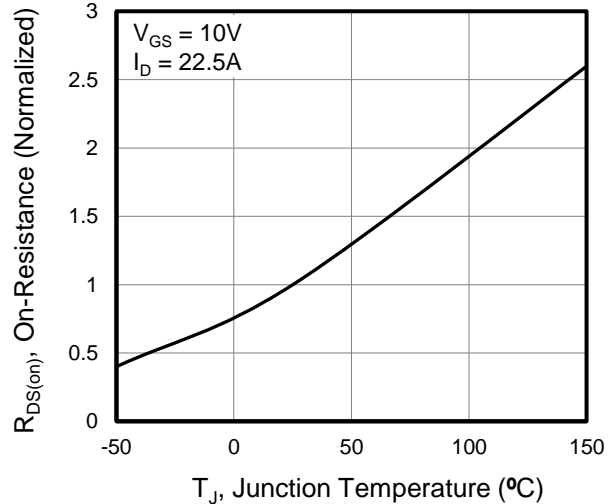
N-Channel Enhancement Mode MOSFET
Typical Characteristics
Figure 1. Output Characteristics ($T_J = 25^\circ\text{C}$)

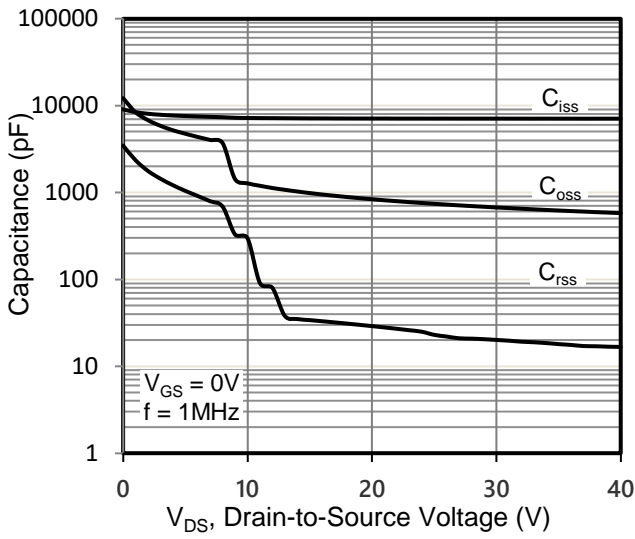
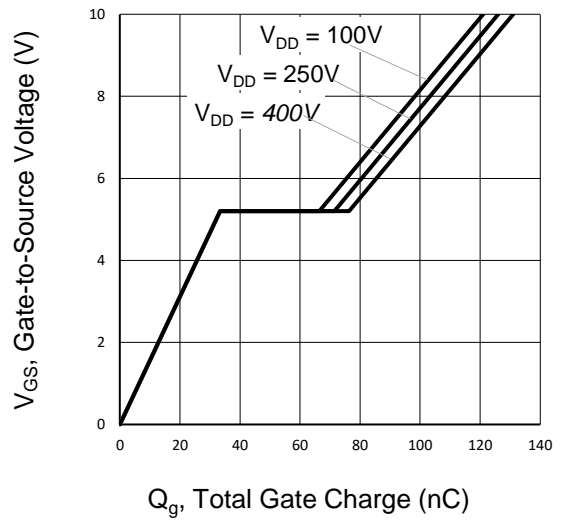
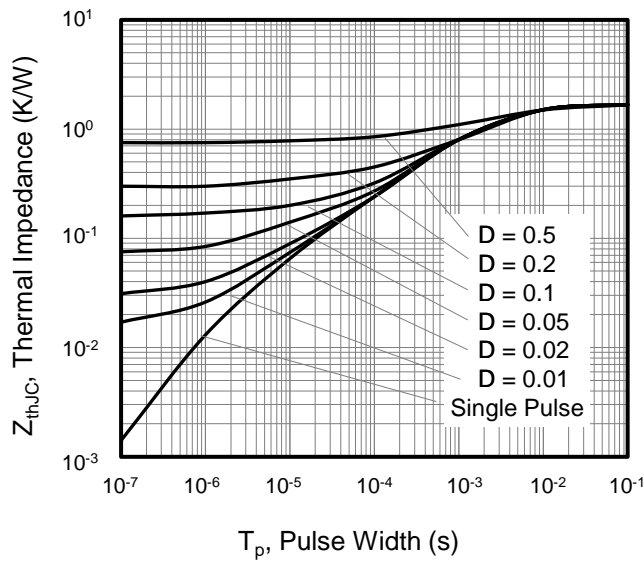
Figure 2. Body Diode Forward Voltage

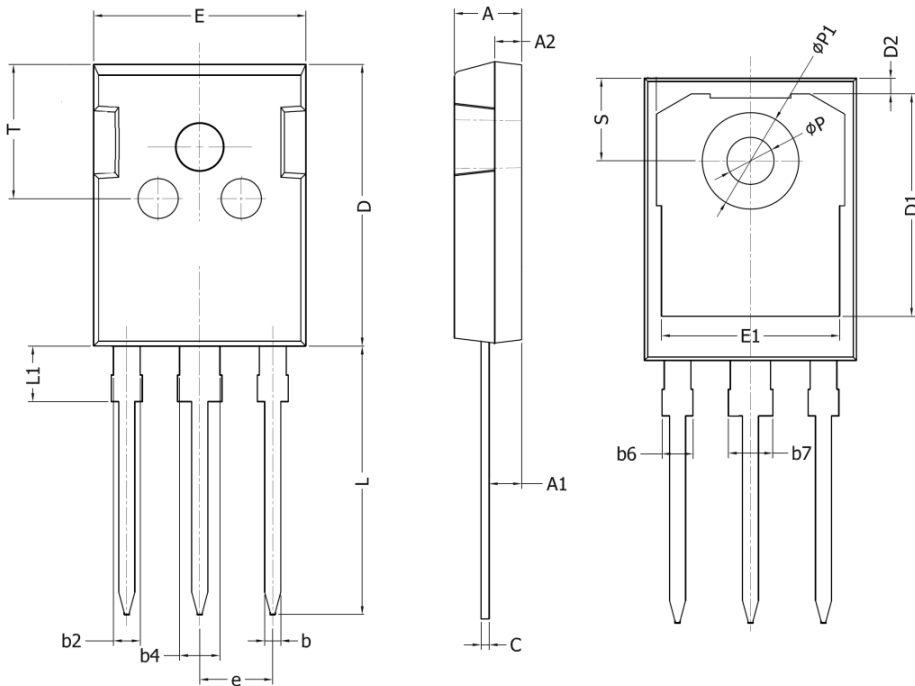
Figure 3. Drain Current vs. Temperature

Figure 4. BV_{DSS} Variation vs. Temperature

Figure 5. Transfer Characteristics

Figure 6. On-Resistance vs. Temperature

N-Channel Enhancement Mode MOSFET
Figure 7. Capacitance

Figure 8. Gate Charge

Figure 9. Transient Thermal Impedance

N-Channel Enhancement Mode MOSFET
TO-247 Package Outline Dimensions

Symbol	Dimensions In Millimeters	
	Min.	Max.
A	4.90	5.20
A1	2.31	2.51
A2	1.9	2.1
b	1.16	1.26
b2	1.96	2.06
b4	2.96	3.06
b6	-	2.25
b7	-	3.25
C	0.59	0.66
D	20.90	21.20
D1	16.25	16.85
D2	1.05	1.35
E	15.75	16.10
E1	13.00	13.60
e	5.436 BSC	
L	19.80	20.20
L1	-	4.30
P	3.40	3.60
P1	7.00	7.40
S	6.05	6.25
T	9.80	10.20