

N-Channel Enhancement Mode MOSFET

Features

- Fast switching speed
- Reliable and Rugged
- ROHS Compliant
- 100% UIS and Rg Tested

Applications

- Switch Mode Power Supply (SMPS)
- Uninterruptible Power Supply (UPS)
- Power Factor Correction (PFC)
- AC to DC Converters

Pin Description

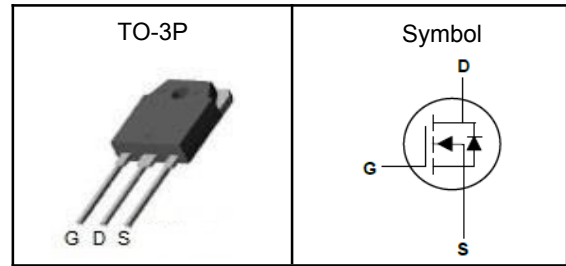

V_{DSS}	500	V
$R_{DS(ON)-Typ}$	0.18	Ω
I_D	26	A

Absolute Maximum Ratings ($T_J=25^\circ\text{C}$, Unless Otherwise Noted)

Symbol	Parameter	N-Channel	Unit
V_{DSS}	Drain-Source Voltage	500	V
V_{GSS}	Gate-Source Voltage	± 30	V
T_J	Maximum Junction Temperature	-55 to 150	$^\circ\text{C}$
T_{STG}	Storage Temperature Range	-55 to 150	$^\circ\text{C}$
E_{AS}	Single Pulse Avalanche Energy ^③	871	mJ
$I_{DM}^{①}$	Pulse Drain Current Tested	104	A
I_D	Continuous Drain Current	$T_c=25^\circ\text{C}$	A
P_D	Maximum Power Dissipation	$T_c=25^\circ\text{C}$	W

Thermal Characteristics

Symbol	Parameter	Rating	Unit
$R_{\theta JA}$	Thermal Resistance Junction-Ambient ₁ (Max)	40	$^\circ\text{C}/\text{W}$
$R_{\theta JC}$	Thermal Resistance Junction-Case ₁	0.43	$^\circ\text{C}/\text{W}$

Note ① : Max. current is limited by bonding wire.

Note ② : UIS tested and pulse width are limited by maximum junction temperature 150 $^\circ\text{C}$.

Note ③ : Surface Mounted on 1in² FR-4 board with 1oz.

**N-Channel Enhancement Mode MOSFET****Electrical Characteristics** ($T_J=25^\circ\text{C}$, Unless Otherwise Noted)

Symbol	Parameter	Test Conditions	Min	Typ	Max	Unit
Static Electrical Characteristics						
BV_{DSS}	Drain-Source Breakdown Voltage	$V_{GS}=0V, I_D=250\mu A$	500	---	---	V
I_{DSS}	Zero Gate Voltage Drain Current	$V_{DS}=500V, V_{GS}=0V$	---	---	1	μA
$V_{GS(th)}$	Gate Threshold Voltage	$V_{DS}=V_{GS}, I_D=250\mu A$	2.5	---	4.5	V
I_{GSS}	Gate Leakage Current	$V_{GS}=\pm 30V, V_{DS}=0V$	---	---	± 100	nA
$R_{DS(ON)}$	Drain-Source On-state Resistance	$V_{GS}=10V, I_D=12.5A$	---	0.18	0.24	Ω
Dynamic Characteristics ^⑤						
C_{iss}	Input Capacitance	$V_{GS}=0V,$ $V_{DS}=25V,$ Freq.=1MHz	---	3130	---	pF
C_{oss}	Output Capacitance		---	340	---	
C_{rss}	Reverse Transfer Capacitance		---	13	---	
$T_{d(on)}$	Turn-on Delay Time	$V_{DD}=250V, R_G=25\Omega,$ $I_D=25A$	---	53	---	nS
T_r	Turn-on Rise Time		---	36	---	
$T_{d(off)}$	Turn-off Delay Time		---	221	---	
T_f	Turn-off Fall Time		---	70	---	
Q_g	Total Gate Charge	$V_{DD}=400V,$ $V_{GS}=10V, I_D=25A$	---	60	---	nC
Q_{gs}	Gate-Source Charge		---	15	---	
Q_{gd}	Gate-Drain Charge		---	22	---	
Source-Drain Characteristics ($T_J=25^\circ\text{C}$)						
V_{SD}	Diode Forward Voltage ²	$V_{GS}=0V, I_S=12.5A, T_J=25^\circ\text{C}$	---	---	1.4	V
t_{rr}	Reverse Recovery Time	$I_S=25A, V_R=250V$ $di/dt=100A/\mu s, T_J=25^\circ\text{C}$	---	370	---	nS
Q_{rr}	Reverse Recovery Charge		---	5	---	nC

Note ④ : Pulse test (pulse width $\leq 300\mu s$, duty cycle $\leq 2\%$).

Note ⑤ : Guaranteed by design, not subject to production testing.

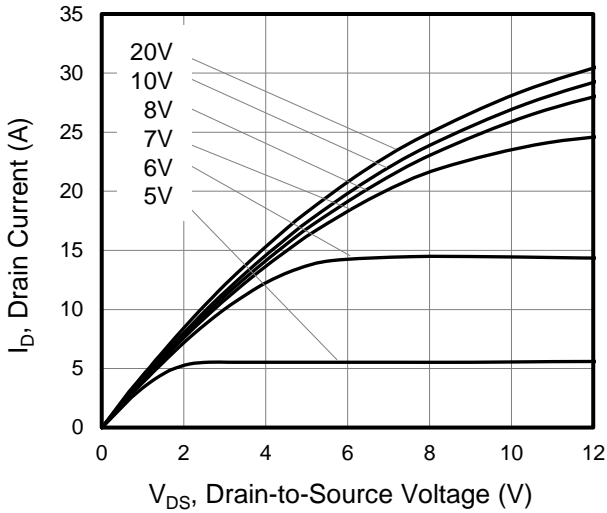
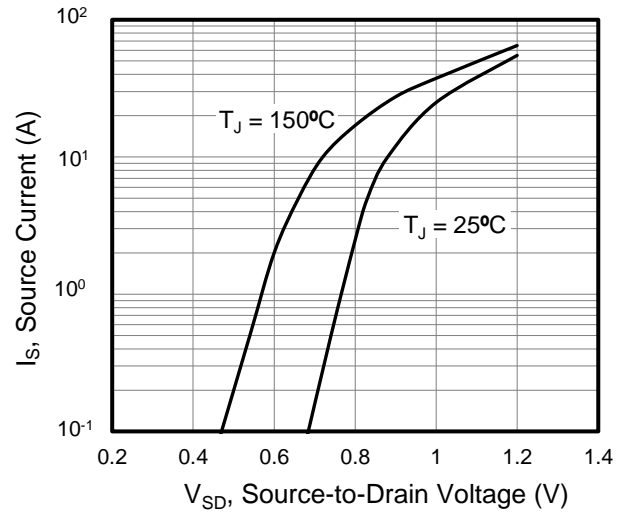
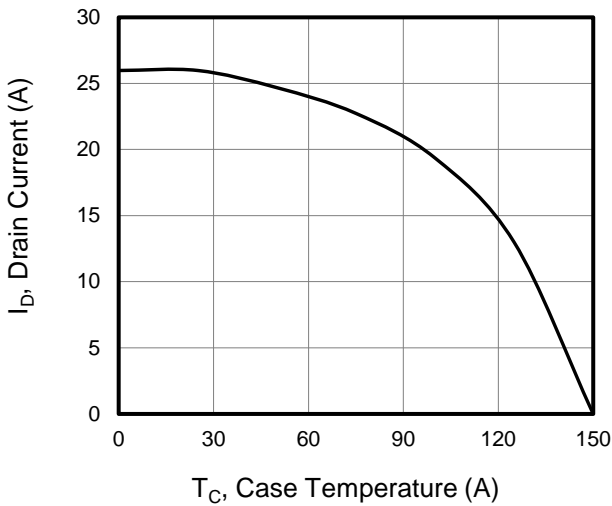
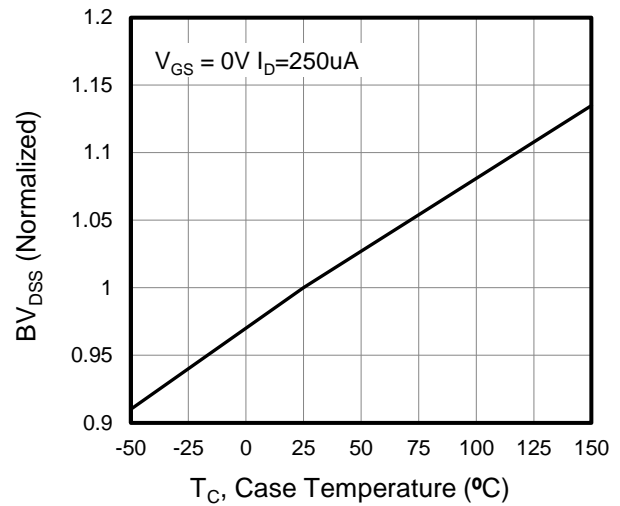
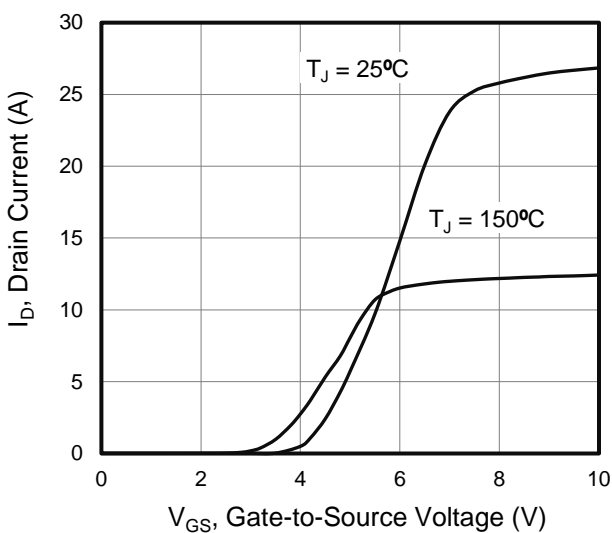
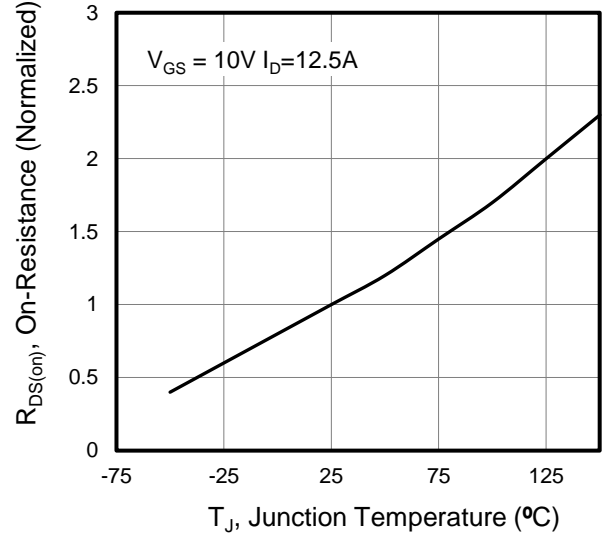
N-Channel Enhancement Mode MOSFET
Typical Characteristics
Figure 1. Output Characteristics ($T_J = 25^\circ\text{C}$)

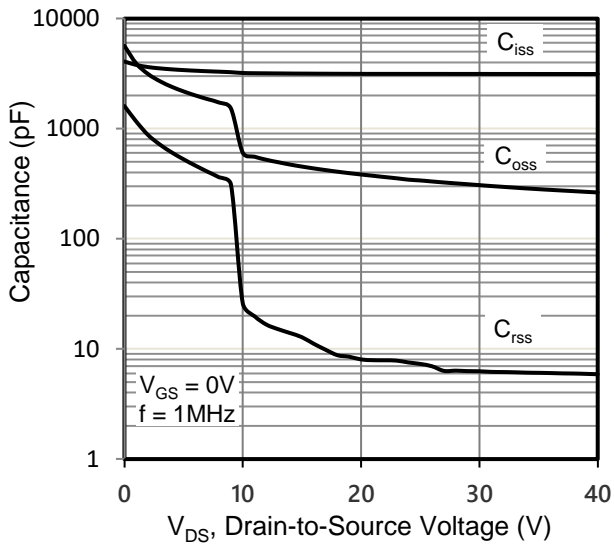
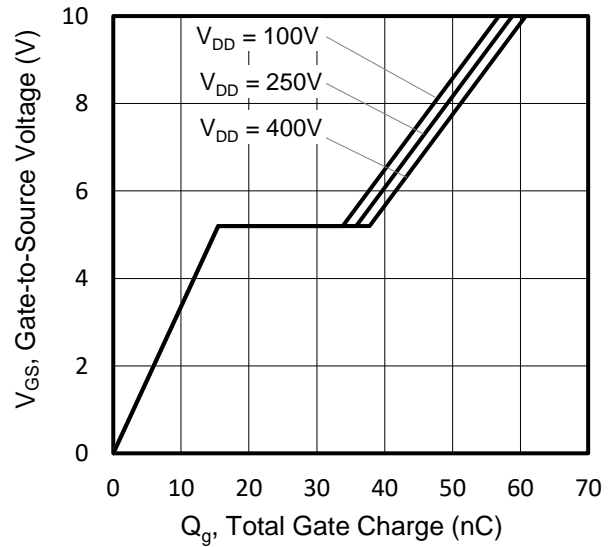
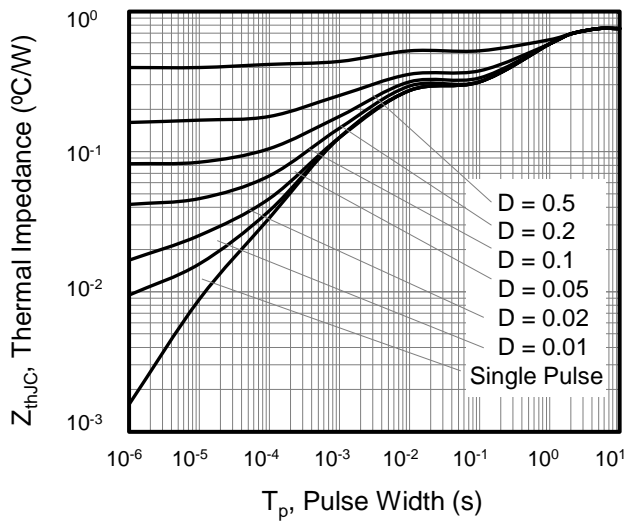
Figure 2. Body Diode Forward Voltage

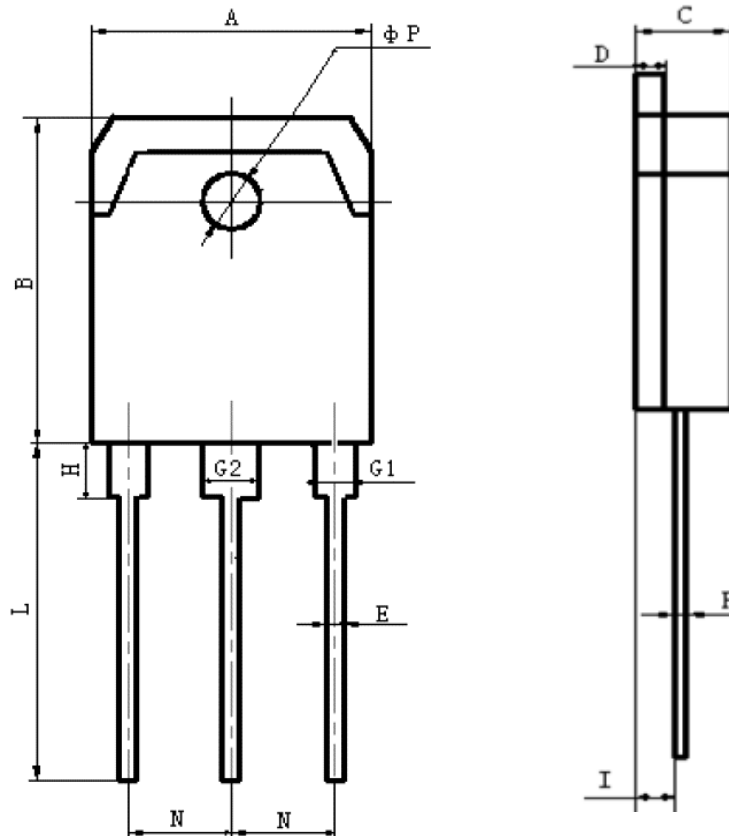
Figure 3. Drain Current vs. Temperature

Figure 4. BV_{DSS} Variation vs. Temperature

Figure 5. Transfer Characteristics

Figure 6. On-Resistance vs. Temperature

N-Channel Enhancement Mode MOSFET
Figure 7. Capacitance

Figure 8. Gate Charge

Figure 9. Transient Thermal Impedance

N-Channel Enhancement Mode MOSFET
TO-3P Package Outline Data

SYMBOLS	MILLIMETERS	
	MIN	MAX
A	15.40	15.80
B	19.70	20.10
C	4.60	5.00
D	1.45	1.65
E	0.80	1.20
F	0.55	0.75
G1	1.80	2.20
G2	2.80	3.20
H	3.30	3.70
I	1.20	1.60
L	19.70	20.30
N	5.25	5.65
ΦP	3.00	3.40